

# 6-Hole Ductile Iron Threaded Flange Specifications

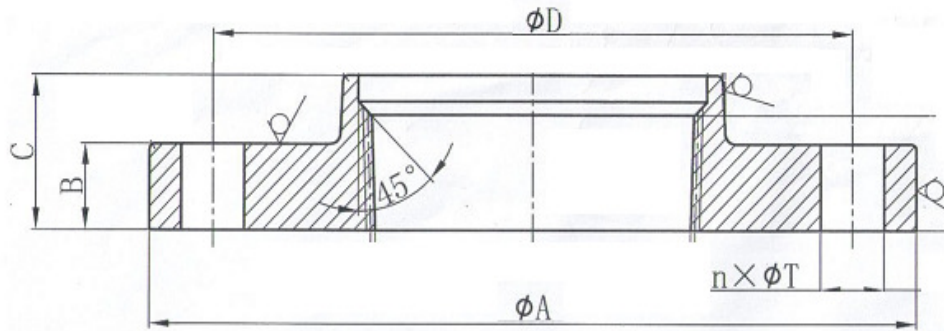

6" Ductile Iron Threaded Flanges  
with 6 Holes for Ductile Iron Pipe  
ANSI / AWWA C115/A21.15  
Ref: DPF066H

UV Item Number	Nom Pipe Size	Flange Outer Diameter (A)	Bolt Circle (D)	B. Hole Diameter (T)	No. of Holes (n)	Flange Thickness (B)	Length Through Hub (C)	Weight (lbs)
DPF066H	6"	11.00	9.50	0.88	6	1.00	2.00	25

All sizes are in Inches

- Dimensions are in inches where applicable; To convert inches to millimeters, multiply by 25.4.
- Ductile Iron ASTM A536 (65-45-12)
- Machined, Drilled & Faced in accordance ANSI B16.1 - Class 125 (only change is No of Bolt Holes 6 instead of 8)
- Rated for a maximum working pressure 250 psi
- Coating : Bare
- Threaded in accordance with ANSI /ASME B 1.20.1