

2

1

B

B

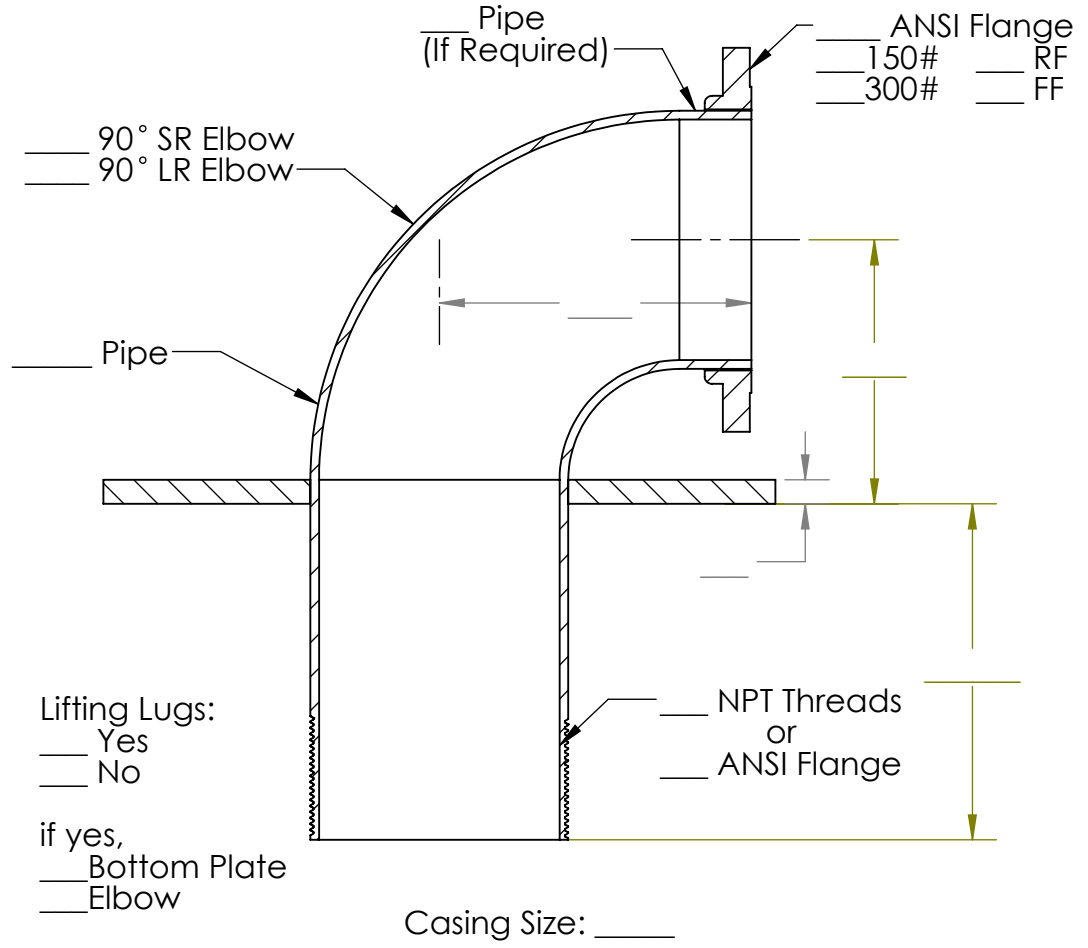
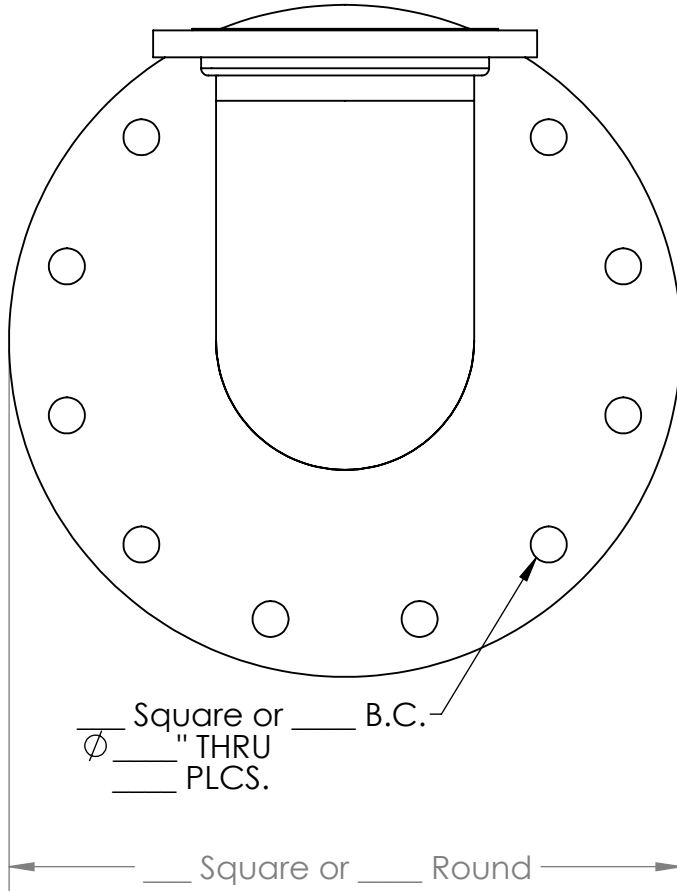

A

A

Add any holes for electrical wiring, probes, sounding tube, etc. if required

UNLESS OTHERWISE SPECIFIED:	NAME	DATE
DIMENSIONS ARE IN INCHES	DRAWN	T. Sanders 7/19/19
TOLERANCES:	CHECKED	
FRACTIONAL ±	ENG APPR.	
ANGULAR: MACH ± BEND ±	MFG APPR.	
TWO PLACE DECIMAL ±	Q.A.	
THREE PLACE DECIMAL ±	COMMENTS:	
INTERPRET GEOMETRIC TOLERANCING PER:	All Welds to be 3/8" Fillet	
MATERIAL		
FINISH		
DO NOT SCALE DRAWING		



TITLE:

Customer:

PROPRIETARY AND CONFIDENTIAL

Material procurement and production for the good identified in this purchase order will not be initiated until Purchaser's approval of the attached drawing, including dimensions and design by an authorized representative of Purchaser. The Purchaser acknowledges the Custom Pipe & Fabrication is not a licensed engineer and does not stamp or sign the drawings it prepares. This drawing is the proprietary property of Custom Pipe & Fabrication Inc. and may not be utilized by the Purchaser for any purposes other than for the approval of manufacture by Custom Pipe & Fabrication Inc.

2

1