

4

3

2

1

D

D

C

C

B

B

A

A

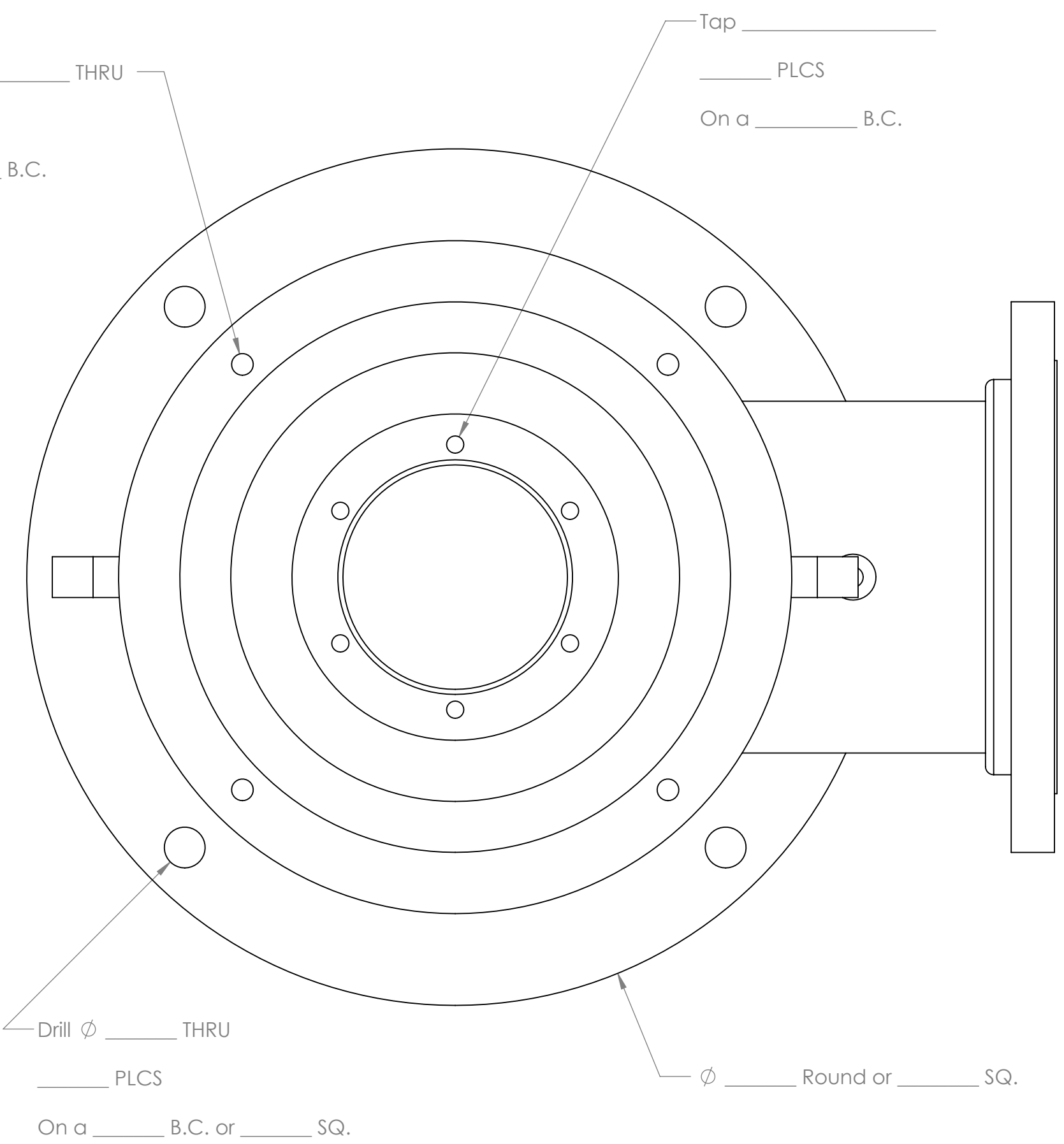
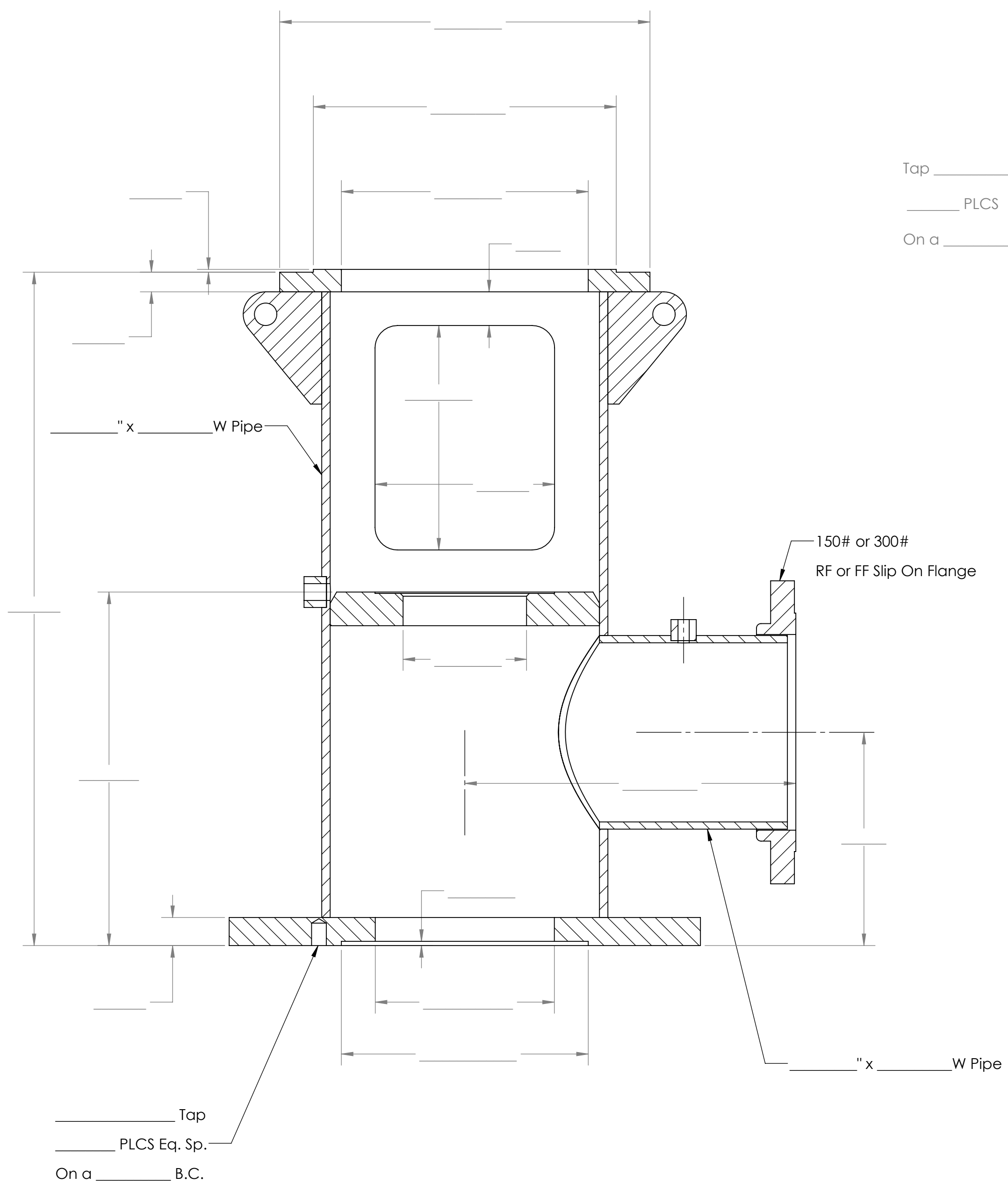

Casing Size: _____"

PROPRIETARY AND CONFIDENTIAL

Material procurement and production for the good identified in this purchase order will not be initiated until Purchaser's approval of the attached drawing, including dimensions and design by an authorized representative of Purchaser. The Purchaser acknowledges the Custom Pipe & Fabrication is not a licensed engineer and does not stamp or sign the drawings it prepares. This drawing is the proprietary property of Custom Pipe & Fabrication Inc. and may not be utilized by the Purchaser for any purposes other than for the approval of manufacture by Custom Pipe & Fabrication Inc.

UNLESS OTHERWISE SPECIFIED:		NAME	DATE
DIMENSIONS ARE IN INCHES	DRAWN	T. Sanders	
TOLERANCES:	CHECKED		
ANGLES $\pm 1.5^\circ$	ENG APPR.		
X.X ± 0.060	MFG APPR.		
X.XX ± 0.030	Q.A.		
X.XXX ± 0.010	COMMENTS:		
Parallel: .003	CONCENTRIC: .003		
MATERIAL			
FINISH			
DO NOT SCALE DRAWING			

TITLE: F & L Head	
DWG. NO.	REV 1
SCALE: 1:8	SHEET 1 OF 1

4

3

2

1